

Cobolt o6-01 Series - High Power

Plug & Play | High Power Multimode Diode Lasers | Modulatable

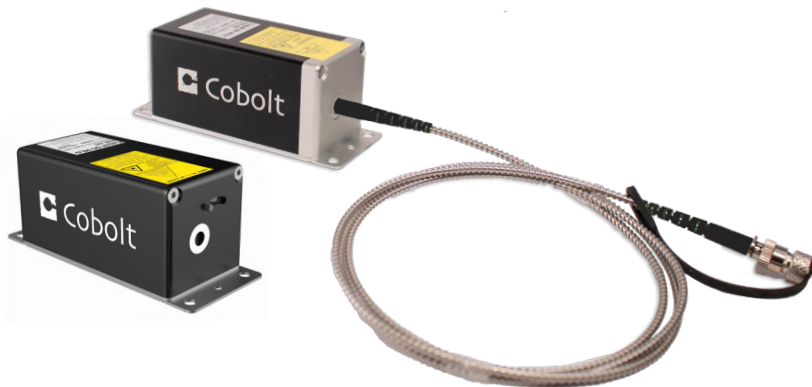

Applications

- Fluorescence microscopy
- Biomedical Imaging
- Super resolution microscopy
- Quantum research
- Laser pumps
- Lithography

- Easy-to-integrate compact and powerful diode laser modules
- Output power up to 1.2 W
- Wavelengths from 405 nm to 975 nm
- Free space and fiber pigtailed beam delivery
- Ultra-robust design
- Fast and deep intensity modulation to a complete dark state
- Versatile modulation controls with linear response to analog power control signals

The Cobolt o6-01 Series high power diode laser modules (o6-HPLD) are high power, multimode, high performance lasers operating at a fixed wavelength, between 405 nm and 975 nm. All included in a compact form factor and an industry standard plug and play format.

The lasers are manufactured using Cobolt's unique HTCure™ Technology to ensure world-class quality and reliability, as well as unmatched robustness.

The Cobolt o6-HPLD lasers offers direct intensity modulation capabilities, allowing fast and deep modulation from versatile input signals. The permanently aligned fiber pigtailed beam delivery option ensures a homogenous intensity distribution, ideal for various fluorescence microscopy and bioimaging applications.

Typical Analog Modulation at 100 kHz
Laser signal in blue, input signal in green.

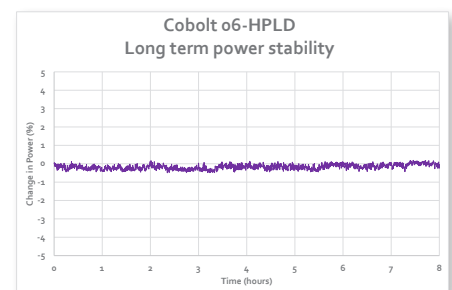
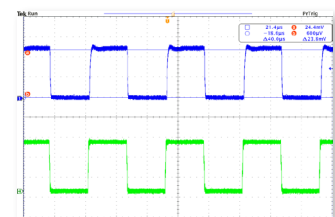

Typical Beam Profile

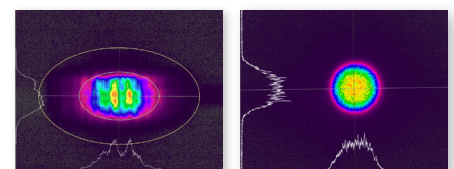

Free beam

Fiber Pigtailed

Cobolt o6-01 Series - High Power

High power multimode diode lasers

The Cobolt o6-01 HPLD lasers are delivered as free beam laser or with a permanently aligned and fixed fiber pigtail using Cobolt's proprietary HTCure™ Technology, providing stable output over a large temperature range and insensitive to transport conditions.



High power multimode laser specifications

	405	425	450	488	520	638	750	830	975
Platform	o6-HPLD								
Center Wavelength (nm)	405 ± 5	425 ± 5	450 ± 10	488 ± 5	520 ± 10	638 ± 6	750 ± 5	830 ± 10	975 -10/+5
Free beam power (mW)	900	1200	1200	1200	800	1200	1200	900	900
Power stability over 8 hrs (%)	< 1.0								
Noise, 20 Hz – 2 MHz (RMS, %)	< 0.2								
Beam dimensions (mm, typ.)	X : 2 ± 1 Y : 2 ± 1								
Fiber pigtailed power (mW)	750	1000	1000	1000	650	1000	1000	750	750
Fiber Output	FC/PC, Narrow key								
Fiber Type	Multimode								
Available core diameter (µm)	50, 105*, 200 or 400					105*, 200 or 400			
Standard Fiber Length (m)	1.0								
Jacketing	Stainless steel								
Warranty	12 months, 5000 hrs								

* Standard fiber core diameter, other core diameters available on request

Operational Environment

Power supply requirements	12 VDC, 3 A
Intended use environment	Laboratory (indoor)
Maximum baseplate temperature	50 °C
Ambient temperature, operation	10 to 40°C
Ambient temperature, storage	-10 to +60°C
Humidity	0-90% RH non-condensing
Ambient Air pressure	800 - 1050 mbar
Laser Head heat sink thermal impedance (at 40°C ambient)	< 0.4 K/W
Maximum heat dissipation of Laser Head	< 25 W



Heatsink HS-07

Model Number

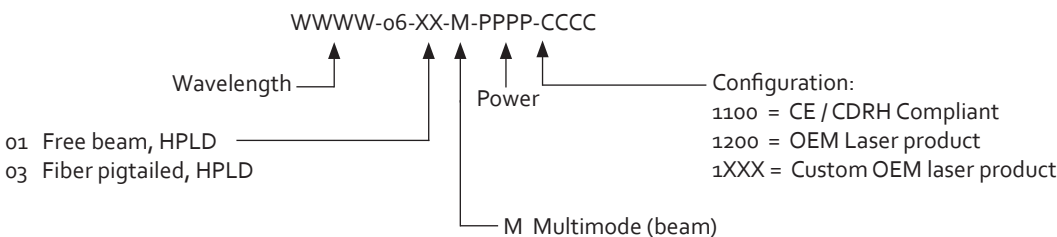

This device is sensitive to Electrostatic Discharge (ESD).



WARNING VISIBLE AND INVISIBLE LASER RADIATION!



Avoid eye or skin exposure to direct or scattered radiation.



Class 4 Laser Product
 Classified per IEC 60825-1:2014



Wvl (nm)	Max.Pwr (W)
405	4.0
425	4.0
450	4.0
488	4.0
520	4.0
638	4.0
750	4.0
830	4.0
975	4.0

Cobolt o6-01 Series - High Power

Modulation Specifications

Digital power modulation	
Modulation frequency	DC - 2 MHz
Rise/fall time	< 50 ns*
Extinction ratio	> 10 000 000 : 1 (> 70dB)
Input signal - Low	0 - 0.8 V
Input signal - High	2 - 5 V
Input signal - Impedance	2 kΩ
Analog power modulation	
Modulation frequency	DC - 100 Hz
Rise/fall time	< 2 ms
Extinction ratio	> 10 000 000 : 1 (> 70dB)
Input signal	0 - 1 V -or- 0 - 5 V
Threshold voltage	37 ± 5 mV (0 - 1 V) 68 ± 5 mV (0 - 5 V)
Input signal - Impedance	2 kΩ -or- 50 Ω
Digital current modulation	
Max. modulation frequency	2 MHz
Rise/fall time	< 50 ns*
Input signal - Low	0 - 0.8 V
Input signal - High	2 - 5 V
Input signal - Impedance	2 kΩ
Analog current modulation	
Max. modulation frequency	2 MHz
Rise/fall time	< 250 ns
Input signal	0 - 1 V -or- 0 - 5 V
Threshold voltage	37 ± 5 mV (0 - 1 V) 68 ± 5 mV (0 - 5 V)
Input signal - Impedance	2 kΩ -or- 50 Ω

* Fall time increased to up to 250 ns for IR wavelengths

Electrical Interfaces

Laser Head

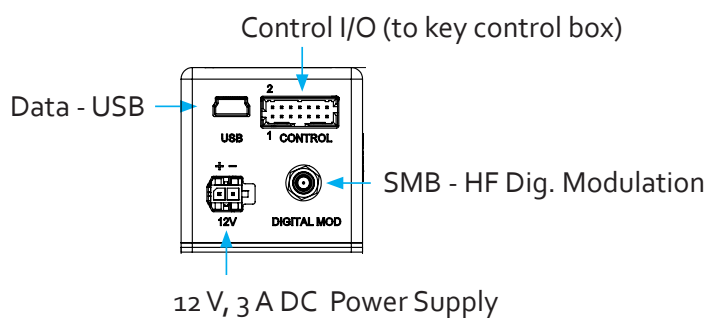

Molex 14 pin - Control I/O (to key control box)

Pin	Function
1	Remote Interlock
2	GND
3	GND
4	RS-232 TX
5	RS-232 RX
6	LED 1B (Laser ON)
7	LED 1A (Laser ON)
8	LED 2 (Error)
9	Digital modulation input (limited to 500 kHz)
10	GND
11	Key switch
12	Remote ON/OFF
13	GND
14	Analog modulation input

Communication Interface

Communication	USB and RS-232
Standard Baudrate	115200

Molex 2 pin - to power supply

Pin	Function
1	+ 12 V DC, max 3 A
2	GND

Cobolt o6-o1 Series - High Power

Mechanical Specifications

Laser head dimensions

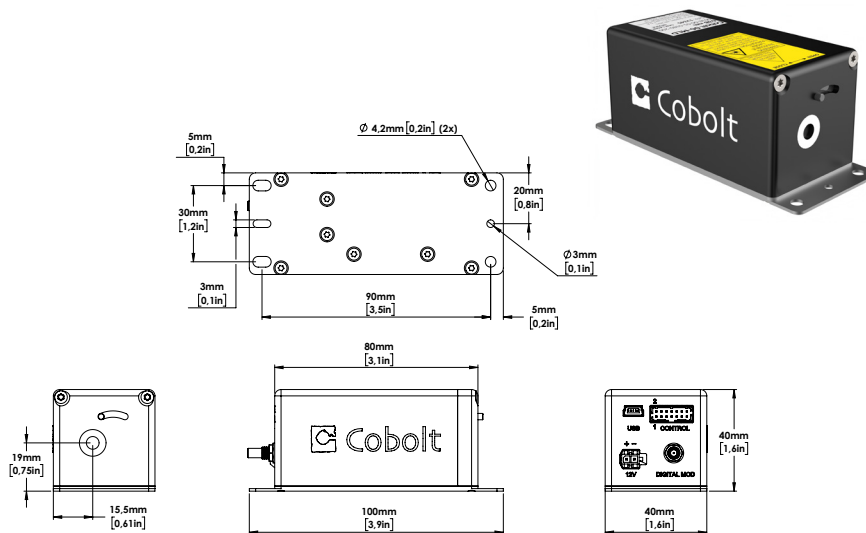

Key control box dimensions

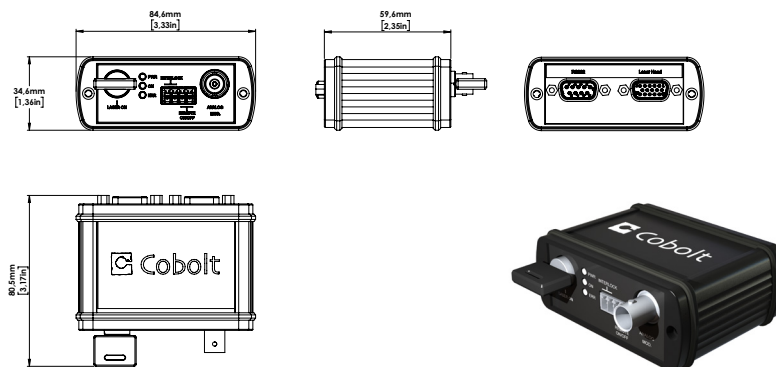

Our Locations

Cobolt AB, a part of HÜBNER Photonics
(Sales in Norway, Sweden, Finland and Denmark)
Solna, Sweden
Phone: +46 8 545 912 30
Fax: +46 8 545 912 31
E-mail: info.se@hubner-photonics.com

HÜBNER Photonics GmbH
(Sales in Germany, Switzerland and Austria)
Kassel, Germany
Phone: +49 561 994 060-0
Fax: +49 561 994 060-13
E-mail: info.de@hubner-photonics.com

HÜBNER Photonics Inc.
(Sales in USA, Canada and Mexico)
San Jose, California, USA
Phone: +1 (408) 708 4351
Fax: +1 (408) 490 2774
E-mail: info.usa@hubner-photonics.com

HA Photonics Pty Ltd
(Sales in UK and Ireland)
London
United Kingdom
Phone: +44 7359 440 871
E-mail: info.uk@hubner-photonics.com

VALO Innovations, a part of HÜBNER Photonics
(VALO Sales and Service)
Hannover, Germany
Phone: +49 511 260 390 70
E-mail: info.valo@hubner-photonics.com

[Find local sales representatives at hubner-photonics.com](http://hubner-photonics.com)